

Preprint of:

M. E. J. Friese, T. A. Nieminen, N. R. Heckenberg, and H. Rubinsztein-Dunlop,
 “Optical torque controlled by elliptical polarization”,
Optics Letters **23**, 1–3 (1998)

Optical torque controlled by elliptical polarization

M. E. J. Friese, T. A. Nieminen,* N. R. Heckenberg, and H. Rubinsztein-Dunlop

*Centre for Laser Science, Department of Physics,
 The University of Queensland, Brisbane QLD 4072, Australia*
 (Dated: 4th August 1997)

We show theoretically and demonstrate experimentally that highly absorbing particles can be trapped and manipulated in a single highly focused Gaussian beam. Our studies of the effects of polarized light on such particles show that they can be set into rotation by elliptically polarized light and that both the sense and the speed of their rotation can be smoothly controlled.

PACS numbers: 42.62.Be,42.62.Eh,42.25.Fx,42.25.Ja

Over the past 20 years the use of light to manipulate microscopic particles has progressed from the more complicated multiple-beam radiation pressure traps of Ashkin [1] and Roosen and Imbert [2] to simpler single-beam traps. The best known of these is the single-beam gradient optical trap (so-called optical tweezers), which can be used to manipulate transparent highindex microscopic particles, or low-index particles if a doughnut-shaped beam is used [3]. This trap is three dimensional in the sense that, as well as experiencing a radial force, a particle experiences an axial force that draws it toward the beam waist, allowing it to be levitated even by a downward-propagating beam. The same experimental arrangement can be used to trap metallic particles three dimensionally if they are small enough to behave as dipoles [4], but larger reflective and absorbing particles experience too large a radiation pressure to be levitated. However, these particles can be trapped radially against a surface (i.e., a two-dimensional trap). Reflective metal particles have been trapped in this way with a Gaussian beam [5], but trapping of micrometer-sized absorbing particles has been limited to traps that use laser beams with a central field minimum, with a high-intensity ring of light to confine the particles to a dark region in the center.

We show both theoretically and experimentally that strongly absorbing particles can in fact be trapped and manipulated by radiation pressure by use of a single Gaussian beam. Moreover, using a Gaussian mode provides a unique opportunity to study the effects of the optical torque on absorbing particles that are due to polarization alone, in contrast to our previous work with an LG₀₃ doughnut mode [6, 7] and that of Simpson et al. [8] where torque owing to orbital angular momentum was also present. Our experiments show that absorbing particles trapped in a Gaussian beam are set into rotation

by elliptically polarized light and rotate in a direction that depends on the handedness of the ellipticity. We also show that particles experience a torque that is due to elliptically polarized light which is proportional to the angular momentum density of the beam.

Two-dimensional trapping of absorbing particles can easily be understood in terms of linear momentum transfer. The force \mathbf{F} experienced by a small area dA of an absorbing particle can be determined from the time-averaged Poynting vector \mathbf{S} by $\mathbf{F} = (1/c)\mathbf{S} \cdot (-dA)(\mathbf{S}/|\mathbf{S}|)$, and the force on a particle can be obtained by integration over its surface. Figure 1 shows the direction and magnitude of the Poynting vector above and below the waist of a focused Gaussian beam. From this, we

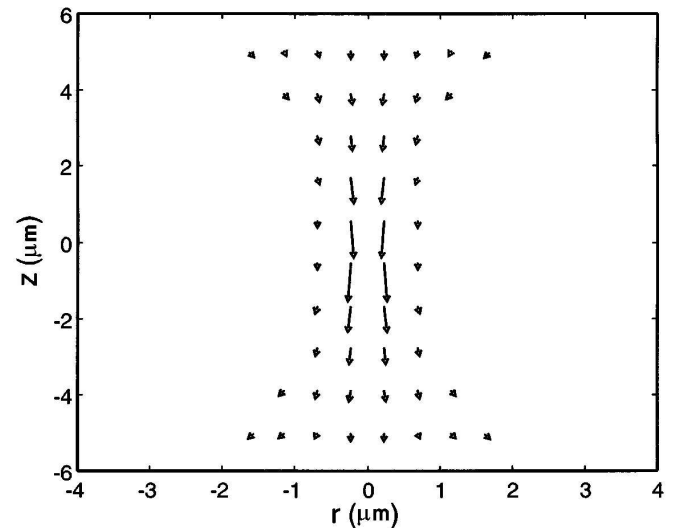

FIG. 1: Linear momentum in a focussed Gaussian laser beam. The direction and magnitude of the Poynting vector above and below the beam waist are shown. As the beam is converging, the Poynting vector has an inward radial component at all points away from the beam axis, which permits two-dimensional radial trapping of absorbing particles.

*timo@physics.uq.edu.au

see that a particle positioned above the waist will experience a force that has a component both in the direction of beam propagation and radially inward, so the particle is confined to the center of the beam. Conversely, a particle below the waist experiences a force in the propagation direction and radially outward, expelling it from the beam center. The radiation pressure force in the direction of beam propagation can be countered by the normal reaction force of the surface on which the particle is trapped. For a given radial trapping force, the unwanted axial pressure will be greater for the Gaussian beam than for a doughnut, increasing friction and causing trapping to be less stable. However, particles trapped in this way can be manipulated, even though these factors make the Gaussian beam trap a little harder to use.

The optical torque from elliptically polarized light, first calculated in 1900 by Sadowsky [9], was considered too small for experimental detection until Beth's famous experiment in 1936 [10], in which this tiny torque was measured in a complicated and difficult experiment. With the additional tools of the laser and the optical trap, it is now possible to observe this torque acting on a microscopic scale [7, 11] with relative ease, as the effects are larger by several orders of magnitude. Optical torque calculations by Marston and Crichton [12], Chang and Lee [13], and Barton et al. [14] indicate that the expected effect of this optical torque on an optically trapped particle is rotation of the order of a few hertz.

To observe the mechanical effects of circularly polarized light, we introduced a $\lambda/4$ plate into an experimental setup based on an optical tweezers arrangement, as shown in Fig. 2. The setup differs from the usual optical tweezers arrangement in that a laser beam is brought to a focus below the specimen plane of a high-power objective to facilitate trapping of absorbing particles. The absorptive material used in these experiments is CuO powder (irregularly shaped particles approximately 1–10 μm in size; refractive index $n = 2.63$) dispersed in kerosene (refractive index $n = 1.442$). The absorptivity of the CuO particles that we used is not known; however, thin films of CuO (50 nm thickness) have been measured to transmit only 30% of 1064 nm light [15], indicating that particles of 1–10 μm thickness would be highly absorbing. A drop of this mixture is placed between a microscope slide and cover slip and then positioned in the specimen plane of a 100 \times high-N.A. oil-immersion objective. A linearly polarized, Gaussian beam ($\lambda = 1064$ nm), spatially filtered with single-mode optical fiber, ≈ 20 mW in power, is directed into the back aperture of the objective and focused to a diffraction-limited spot below the particle, which is then optically trapped.

When circularly polarized light is absorbed by a particle, by conservation of angular momentum we expect that the particle will gain mechanical angular momentum and thus experience a torque. The torque τ acting on a particle of radius r and absorptivity α trapped on the axis of a beam of spot size $w(z)$ is given by $\tau = (\alpha\sigma_z P/\omega)(1 - \exp\{-2r^2/w^2(z)\})$, where P is the

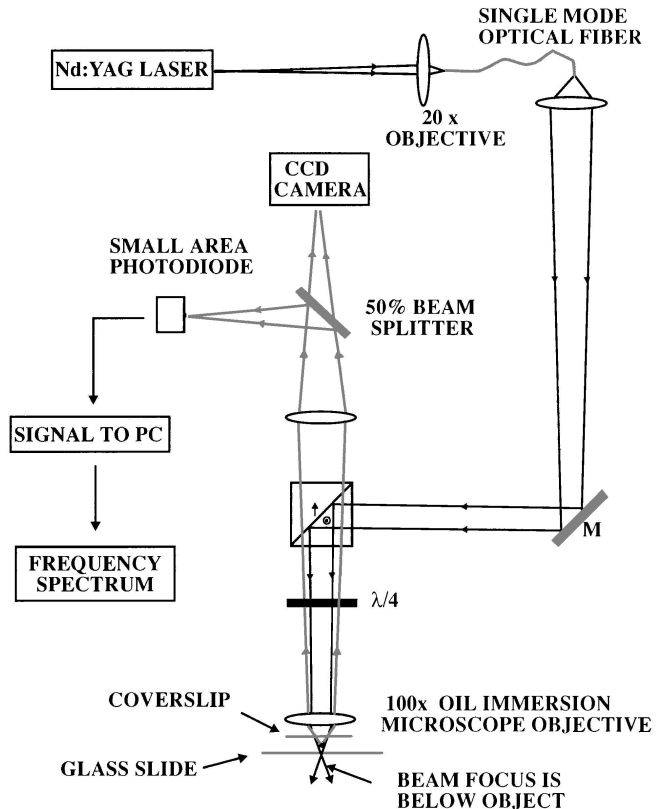

FIG. 2: Experimental setup for optical trapping and micro-manipulation of absorbing particles by use of a Gaussian laser beam. The particles are trapped above the waist of the beam. The quality of the beam is ensured to be Gaussian by optical filtering with a single-mode optical fiber.

beam power, $w(z)$ is the beam width, ω is the angular frequency of the light, and σ_z is the degree of circular polarization, equal to ± 1 for left- and right-circularly polarized light, respectively, and 0 for plane-polarized light. For a particle rotating with angular speed Ω in a medium of viscosity η , the drag torque is given by $\tau_D = -8\pi\eta r^3\Omega$ and the particle rotation rate will be constant when these torques are equal. For example, a CuO particle in kerosene [assumed to be at 100°C with viscosity of 5.5×10^{-4} Ns/m²] absorbing 10% of a 20 mW beam should rotate at 10 Hz in circularly polarized light, either clockwise or anticlockwise about the beam axis, depending on whether the light is left- or right-circularly polarized. This estimate is in agreement with our observed rotation rates of 1–25 Hz.

In our experiment we changed the beam polarization from plane to circular through rotation of a $\lambda/4$ plate while keeping a CuO particle trapped and observed that, on rotation of the wave plate, the particle began to rotate at a frequency of a few hertz. All the particles that we tested rotated in the same direction, and, on rotation of the $\lambda/4$ plate by 90°, all trapped particles changed direction and continued to rotate. Particles did not rotate in plane-polarized light.

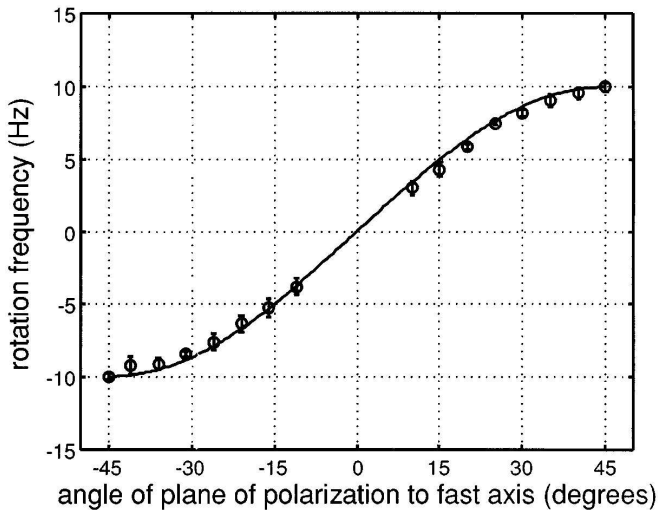

FIG. 3: Particle rotation as a result of the torque from elliptically polarized light. The rotation frequency for absorbing particles trapped in a Gaussian beam is shown as a function of θ , the angle between the fast axis of the $\lambda/4$ plate and the plane of polarization of the incoming laser beam. The solid curve represents the expected variation of rotation rate with θ as calculated from Eq. (1).

The angular momentum density \mathbf{J} is given by $\mathbf{J} = (\epsilon/2i\omega) \int d^3r \mathbf{E}^* \times \mathbf{E}$, where \mathbf{E} is the electric field amplitude vector [16]. For elliptically polarized light produced by passing plane-polarized light through a $\lambda/4$ plate, the electric field vector can be written as $\mathbf{E} = E_0 \cos \theta \hat{\mathbf{j}} + iE_0 \sin \theta \hat{\mathbf{k}}$, giving

$$\mathbf{J} = -\frac{\epsilon}{2\omega} E_0^2 \sin 2\theta \hat{\mathbf{i}}, \quad (1)$$

where θ is the angle between the fast axis of the $\lambda/4$ plate and the electric field of the plane polarized incident field.

We can measure the rotation frequency of a trapped CuO particle by using a small-area photodiode placed off center of the image of the scattered light from the particle [7], as shown in Fig. 2. To quantify the effects of elliptically polarized light we rotated a $\lambda/4$ plate in increments of 5° from $\theta = -45^\circ$ to $\theta = +45^\circ$, thus changing the polarization stepwise from left to right circular. At each position we measured the particle's rotation frequency, which we plot in Fig. 3 against the angle of the $\lambda/4$ plate. Also plotted in Fig. 3 is a graph of $f_{\max} \sin 2\theta$, which is the calculated rotation frequency from Eq. (1), where f_{\max} is the frequency of rotation in circularly polarized light. As can be seen from the graph, the experimental data fit the theoretical curve extremely well, confirming that the particle rotation is in fact a result of the torque from elliptically polarized light. Once the rotation rate for a particular particle in circularly polarized light is known, we can control both its direction and rate of rotation simply by rotation of a $\lambda/4$ plate.

We have shown that it is possible to trap and manipulate strongly absorbing microscopic particles two dimensionally without the requirement for a doughnut beam, production of which can present substantial complications within a conventional optical tweezers arrangement. Our investigation of polarization effects shows that absorbing particles can be rotated without the use of a helical doughnut beam and that, by varying varying the ellipticity and handedness of the trapping beam polarization, we have continuous smooth control of the rotation. This experiment provides a direct and easily set up demonstration of the angular momentum of elliptically polarized light.

-
- [1] A. Ashkin, *Sci. Am.* 226, 62 (1972).
 - [2] G. Roosen and C. Imbert, *Opt. Commun.* 26, 432 (1978).
 - [3] K. T. Gahagan and G. A. Swartzlander, Jr., *Opt. Lett.* 21, 827 (1996).
 - [4] K. Svoboda and S. M. Block, *Opt. Lett.* 19, 930 (1994).
 - [5] S. Sato, Y. Harada, and Y. Waseda, *Opt. Lett.* 19, 1807 (1994).
 - [6] H. He, M. E. J. Friese, N. R. Heckenberg, and H. Rubinsztein-Dunlop, *Phys. Rev. Lett.* 75, 826 (1995).
 - [7] M. E. J. Friese, J. Enger, H. Rubinsztein-Dunlop, and N. R. Heckenberg, *Phys. Rev. A* 54, 1593 (1996).
 - [8] N. B. Simpson, K. Dholakia, L. Allen, and M. J. Padgett, *Opt. Lett.* 22, 52 (1997).
 - [9] A. Sadowsky, *Acta Comment. Imp. Universit. Jurievensis* 7, 1 (1899); 8, 1 (1900).
 - [10] R. A. Beth, *Phys. Rev.* 50, 115 (1936).
 - [11] T. Sugiura, S. Kawata, and S. Minami, *J. Spectrosc. Soc. Jpn.* 11, 1342 (1990).
 - [12] P. L. Marston and J. H. Crichton, *Phys. Rev. A* 30, 2508 (1984).
 - [13] S. Chang and S. S. Lee, *J. Opt. Soc. Am. B* 2, 1853 (1985).
 - [14] J. P. Barton, D. R. Alexander, and S. A. Schaub, *J. Appl. Phys.* 66, 4592 (1989).
 - [15] N. Özer and F. Tepehan, *Solar Energy Mater. Solar Cells* 30, 13 (1993).
 - [16] S. M. Barnett and L. Allen, *Opt. Commun.* 110, 670 (1994).